

1.1 INSTALLATION ORDER

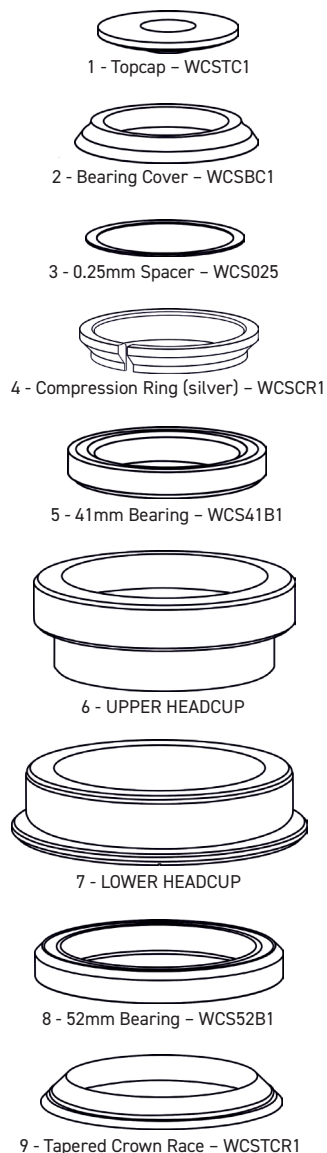

INSTALLATION GUIDE

Thank you for purchasing a product from Works Components - Firstly, we recommended that you take the installation of this product to your local bike shop if you are not a confident home mechanic.

- 1 - Remove current headset and crown race if applicable.
- 2 - Inspect headtube for damage & measure to confirm correct size.
- 3 - Find and mark the centre-point of the headtube by measuring, using a straight edge or string tied to seat post and pulled taught down length of bike.
- 4 - Apply small coat of suitable grease (Ensure carbon friendly if required)
- 5 - Headcups must be installed with correct orientation as can be seen in figure 1.3
- 6 - Upper Cup - bearing is offset, install as shown in figure 1.2 - offset towards rear of bike to slacken angle, away from rear of bike to steepen angle.
Lower Cup - bearing is not offset - engraved letter 'R' is used to show orientation and is installed towards rear of bike to slacken angle, away from rear of bike to steepen angle.
- 7 - Ensure cups are pushed fully home into headtube with no visible gaps.
- 8 - Apply grease to face of bearings, compression ring & crown race, install crown race to steerer tube and insert fork and install remaining components as shown in figure 1.1
- 9 - Pre-load headset to remove bearing play - tighten stem to manufacturer specification, handlebar should turn freely with no restriction.

1.3 HEADCUPS FROM ABOVE

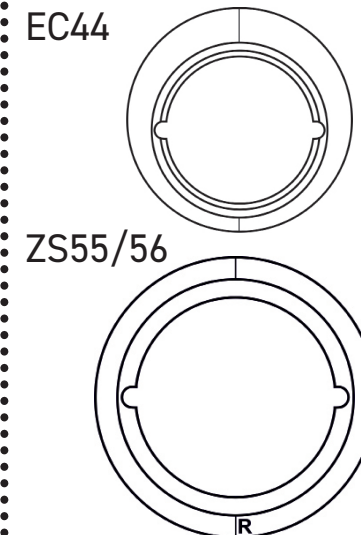

1.2 HEADCUP ORIENTATION

UPPER CUP (EC44)

SLACK

STEEP

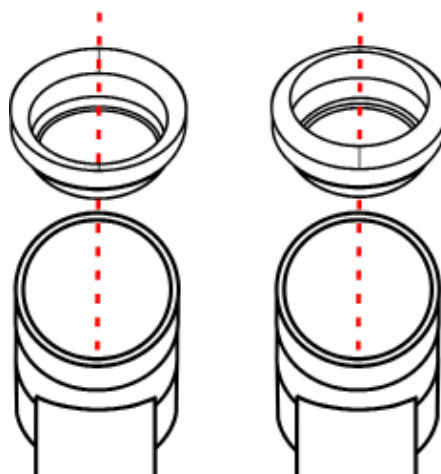

LOWER CUP (ZS55/56)

SLACK

STEEP

